



We help ideas meet the real world

EU Type Examination Certificate

No. DK 0199.379 Revision 2

**ASP / ATP / AHP / AHPS / AHW / AHC / QSP / QTP /
QHW / QHC**

NON-AUTOMATIC WEIGHING INSTRUMENT

Issued by DELTA Danish Electronics, Light & Acoustics
EU - Notified Body No. 0199

In accordance with the requirements in Directive 2014/31/EU of the European Parliament and Council.

Issued to Tscale Electronics Mfg. (Kunshan) Co., Ltd.
No. 99 Shunchang Road,
Zhoushi, Kunshan, Jiangsu
CHINA

In respect of Non-automatic weighing instrument designated ASP / ATP / AHP / AHPS / AHW / AHC / QSP / QTP / QHW / QHC with variants of modules of load receptors and load cells.
Accuracy class III, single-interval, dual-range or dual-interval
Maximum capacity, Max: From 3 kg to 30 kg
Verification scale interval: $e_i = \text{Max}_i / n_i$
Maximum number of verification scale intervals: $n = 3000$ or 2×3000 .
Variants of models are set out in the annex.

The conformity with the essential requirements in annex 1 of the Directive is met by the application of the European Standard EN 45501:2015 and OIML R76:2006.

Note: This certificate is a revised edition which replaces previous revisions.

The principal characteristics and approval conditions are set out in the descriptive annex to this certificate.

The annex comprises 15 pages.

Issued on 2016-08-16
Valid until 2023-03-26

Signatory: J. Hovgård

DELTA
Venlighedsvej 4
2970 Hørsholm
Denmark

Tel. (+45) 72 19 40 00
Fax (+45) 72 19 40 01
www.delta.dk
VAT No. DK 12275110

Descriptive annex

Contents		Page
1.	Name and type of instrument	2
2.	Description of the construction and function	2
2.1	Construction	2
2.2	Function	3
3.	Technical data	6
3.1	Scales	6
3.2	Load cells	6
3.3	Documents	6
4.	Interfaces and peripheral equipment	6
4.1	Interfaces	6
4.2	Peripheral equipment	6
5.	Approval conditions	7
5.1	Measurement functions other than non-automatic functions	7
5.2	No consecutive tare	7
5.3	Connection to POS system	7
5.4	Counting operation is not approved for NAWI	7
5.5	Pre-set tare	7
6.	Special conditions for verification	7
7.	Securing and location of seals and verification marks	7
7.1	Securing and sealing	7
8.	Location of CE mark of conformity and inscriptions	8
8.1	Scale	8
9.	Pictures	9

1. Name and type of instrument

The non-automatic weighing instruments designated ASP / ATP / AHP / AHPS / AHW / AHC / QSP / QTP / QHW / QHC are self-indicating desktop scales of class III with single-interval/dual-range/dual-interval, an external AC/DC mains adapter, and an internal rechargeable battery (optional).

ASP / ATP / AHP / AHPS / QSP / QTP are price computing scales intended for sales to the public.

Each scale consists of analogue to digital conversion, microprocessor control, power supply, keyboard, non-volatile memory for storage of calibration and weight data and a display contained within a single enclosure. ATP / AHP / QTP have an additional rear display, while ASP / AHPS / QSP have an additional display placed in a separate enclosure on a pole.

2. Description of the construction and function

2.1 Construction

Enclosure

The scale is housed in a plastic enclosure. The display is placed on the front together with the keyboard. It is intended to be used in shops as well as industrial environments.

A level indicator is built into the enclosure near the display.

Keyboard

The AHW / QHW's keyboard contains 7 keys used to control the functions of the scale, while the AHP / AHPS's keyboard contains 24 keys including 0 – 9, and the ASP / ATP / AHC / QSP / QTP / QHC's keyboard contains 20 keys including the digits 0 – 9.

Display

AHW / QHW.

The display comprises of a 7-segment LCD-display with white LED backlight with 6 digits and appropriate status indicators. The scale may have an identical second display placed at the rear of the scale

AHC / QHC.

A front display is consisting of three individual displays – Weight, Unit Weight and Count – which each comprise of a 7-segment LCD-display with white LED backlight with 6 digits and appropriate status indicators. The scale may have a rear display identical to the front display.

ATP / QTP / AHP.

A front display and a rear display each consists of three individual displays – Weight, Unit Price and Total Price – which each comprising of a 7-segment LCD-display with white LED backlight with 6 digits and appropriate status indicators.

ASP / QSP / AHPS.

A front display and a pole display each consists of three individual displays – Weight, Unit Price and Total Price – which each comprising of a 7-segment LCD-display with white LED backlight with 6 digits and appropriate status indicators.

Electronics

The instruments have one main board and one or more display board(s).

Models

Model	Max	e	Min	Modem	No of Load cells	Load cell type	E _{max}
ASP	3 kg	1 g	20 g	Single interval	1	ZEMIC L6D C3	5 kg
ATP	6 kg	2 g	40 g			10 kg	
AHP	15 kg	5 g	100 g			20 kg	
AHPS	30 kg	10 g	200 g			40/50 kg	
AHW	3/6 kg	1/2 g	20/40 g			10 kg	
AHC	6/15 kg	2/5 g	40/100 g	Multi-range		20 kg	
QSP	15/30 kg	5/10 g	100/200 g			40/50 kg	
QTP	3/6 kg	1/2 g	20 g			10 kg	
QHW	6/15 kg	2/5 g	40 g	Multi-interval		20 kg	
QHC	15/30 kg	5/10 g	100 g			40/50 kg	

2.2 Function

The weight indicating instruments are microcontroller based self-indicating electronic price computing scales / weighing scales / counting scales. The instruments are available for operation from mains at 230 VAC 50 Hz using an external AC/DC adapter with 9 - 12 VDC output voltage and an optional internal 6V rechargeable battery.

The primary functions provided are detailed below.

2.2.1 Power-up

On power-up, the scale will first display the software version for 2 seconds and then perform a display test. After that it will automatically establish the current weight as a new zero reference.

2.2.2 Test function

On power-up, the scale will test all memory functions followed by a display test. The display test consists of counting down the numeric digits from 9 to 0, while all indicators are on.

2.2.3 Display range

The scales will display weight from -Max (tare function) to Max +9e (gross weight).

2.2.4 Zero-setting

Zero-setting range: $\pm 2\%$ of Max.

Initial zero-setting range: $\leq \pm 10\%$ of Max.

Zero-setting is only possible when the load receptor is not in motion.

2.2.4.1 Semi-automatic zero-setting

Pressing the ZERO key causes a new zero reference to be established and ZERO annunciator to turn on, indicating that the display is at the centre of zero.

2.2.5 Zero-tracking

The scales are equipped with a zero-tracking feature which operates over a range of ± 2 % of Max and only when the scale is at gross zero and there is no motion in the weight display.

2.2.6 Tare

The instrument models are provided with a semi-automatic subtractive tare.

2.2.6.1 Semi-automatic tare

The instrument models are provided with a semi-automatic subtractive tare.

Pressing the "TARE" key will enter the currently weight value as the new tare weight value, if the tare function is not already active. The weight display will automatically change to the net weight display mode and turn on the NET annunciator. This tare value can be cleared by pressing the TARE key, when there is no load on the load receptor. This tare entry cannot take place, if the load receptor is in motion.

2.2.6.2 Pre-set tare

The AHC / QHC scales are provided with a pre-set tare.

Keying in a numeric value and pressing the "TARE" key will take the entered value as a pre-set tare value. The combined unit weight / pre-set tare display will show the pre-set tare value temporary.

The indicator can store up to 100 pre-set tare values in its lookup table.

2.2.7 Price Look Up (PLU)

The ASP / ATP / QSP / QTP scales can store 10 unit price values. These are accessed using the PLU key and a numeric key.

The AHP / AHPS scales have 6 keys (M1 to M6) for direct unit price look up. In addition the scale can store up to 99 indirect PLU values, which are accessed using the PLU key and the numeric keys.

2.2.8 Hold unit price

On AHP / AHPS pressing the SAVE key for 3 seconds will toggle the save function between on and off. When the SAVE indicator is on, the automatic unit price clear at zero weight is disabled, and when the automatic unit price clear at zero weight is enabled, the indicator is off.

2.2.9 Totalisation

The ASP / ATP / AHW / AHC / QSP / QTP / QHW / QHC scales have a totalisation function for accumulating transactions. On ASP / ATP / QSP / QTP the totalisation function is to be disabled unless the optional RS-232 interface is installed and a printer is connected.

2.2.10 Printing

A printer may be connected to the optional serial data port.

The AHC / QHC scales will print the current result when the M+ key is pressed for accumulation of the result. They will also print the current result if the PRINT key is pressed.

The AHW / QHW scales will transmit the current result to the printer and also accumulate it when the PRINT key is pressed.

The ASP / ATP / QSP / QTP price computing scales automatically print the result when the transaction is accumulated using the M+ key. Pressing the ACCOUNT key will print out the accumulated result

The printing will not take place if the load receptor is not stable, if the gross weight is less than zero, or if the weight exceeds Max.

2.2.11 Counting

The AHC / QHC scales are primary intended for counting while AHW / QHW have a simplified counting function.

The count shown in counting mode however, is not to be regarded as an approved weighing result.

2.2.12 Check weighing

The AHW / AHC / QHW / QHC scales have a non-automatic check weighing function where the weighing result is compared against an upper and a lower limit.

2.2.13 Percentage weighing

Pressing the “%” key on AHW / QHW will toggle between normal weighing mode and percentage weighing mode. The value shown in percentage mode is not to be regarded as an approved weighing result.

2.2.14 Extended resolution (×10)

The scales that are not price computing have an extended resolution function. Pressing the key will show the weight with $d = 0.1e$ for 5 seconds.

2.2.15 Operator information messages

The weight display can show a number of general and diagnostic messages, which are described in detail in the User’s Manual.

2.2.16 Software version

The scales have now software separation. The legally relevant software version is 1.10 and the application software has version 1.xx, where xx can be 00 to 99

The application software version is displayed during the power-up sequence of the instrument.

The legal relevant software version can be displayed by pressing the following key(s) during the power-up sequence of the instrument,

ATP/ASP/QTP/QSP/AHP/AHPS:	backlight and M+ keys
AHC/QHC:	C key
AHW/QHW:	% key

The scales that were produced earlier did not have software separation and had the following approved software versions,

ASP / ATP :	1.018
QSP / QTP :	1.015
AHW / QHW:	2.011
AHC / QHC:	1.013

which were displayed during the power-up sequence.

2.2.17 Battery operation

The scale models are supplied with 9 - 12 VDC from an external AC/DC adapter and can be operated from an optional internal 6V rechargeable battery. The scale contains the circuitry necessary to recharge the battery when the scale is connected to the mains power.

2.2.18 Gravity compensation

If the scale is to be used a different place than the one of verification, then the g-value for the place of verification shall be entered into the 'Gra' parameter, before the calibration and verification is performed. After the verification the parameter shall be set to the g-value for the place of use. This adjustment is sealed.

3. Technical data

3.1 Scales

The ASP / ATP / AHP / AHPS / AHW / AHC / QSP / QTP / QHW / QHC scales have the following characteristics:

Accuracy class:	III
Weighing range:	Single-interval or dual range or dual-interval
Maximum number of Verification Scale Intervals:	3000 (single-interval), 2×3000 (multi range), 2×3000 (multi-interval)
Maximum capacity (Max):	3 kg to 30 kg
Verification Scale Interval(e):	≥ 1 g
Minimum capacity (Min):	20 e
Maximum tare effect:	≤ -Max
Excitation voltage:	5 VDC
Mains power supply:	9 - 12 VDC / 230 VAC, 50 Hz using external AC/DC adapter
Operational temperature:	-10 °C to +40 °C
Peripheral interface:	Set out in Section 4

3.2 Load cells

Tscale load cell type BX6 C3 or Zemic load cells type L6D C3 according to the table in Section 2.1 and with $v_{\min} \leq e_1$.

3.3 Documents

The documents filed at DELTA (reference No. T203600) are valid for the weighing instruments described here.

4. Interfaces and peripheral equipment

4.1 Interfaces

The interfaces are characterised “Protective interfaces” according to paragraph 8.4 in the Directive.

4.1.1 RS-232 interface

The scales may be equipped with a RS-232 interface for connection to a computer or to a printer.

4.2 Peripheral equipment

The instrument may be connected to any simple printer with a CE mark of conformity using a screened cable.

5. Approval conditions

5.1 Measurement functions other than non-automatic functions

Measurement functions that will enable the use of the instrument as an automatic weighing instrument are not covered by this type approval.

5.2 No consecutive tare

Consecutive tare operation shall be disabled on the price-computing scales.

5.3 Connection to POS system

The scales may be connected to a POS system (Point Of Sale / Electronic Cash Register), if this has a Test Certificate, an Evaluation Certificate or a Part Certificate issued by a body notified for type examination under Directive 2014/31/EU.

5.4 Counting operation is not approved for NAWI

The count shown as result of the counting function is not covered by this NAWI approval.

5.5 Pre-set tare

If a AHC / QHC scale is configured with pre-set tare, it shall be marked:
'Not to be used for direct sale'.

6. Special conditions for verification

None.

7. Securing and location of seals and verification marks

7.1 Securing and sealing

Seals shall bear the verification mark of a notified body or alternative mark of the manufacturer according to ANNEX II, module F or D of Directive 2014/31/EU.

7.1.1 Scale

Access to the configuration and calibration facility is achieved by pressing a calibration switch accessed through a hole in the bottom of the enclosure of the scale. Sealing of the access to the calibration switch is accomplished by a sticker covering the hole through which the switch is accessed.

Sealing of the enclosure can be done in two ways.

Method A: Sealing of the access to the inside of the enclosure is accomplished by a placing a rod through the enclosure and seal it with wire and lead/plastic seal.

Method B: Sealing of the access to the inside of the enclosure is accomplished by an additional sticker covering one of the assembling screws of the enclosure.

8. Location of CE mark of conformity and inscriptions

8.1 Scale

8.1.1 CE mark

CE mark and supplementary metrological marking shall be applied to the scale according to article 16 of Directive 2014/31/EU.

8.1.2 Inscriptions

Max_i, Min_i, and e_i shall be located near the display(s).

On a label located on the side of the scale enclosure:

- Manufacturer's name or trademark plus postal address
- Type designation
- Max, min, e = , d =
- Tare (if T ≠ -Max)
- EC type approval certificate number

Model no., serial no., electrical data and other inscriptions

9. Pictures



Figure 1 ASP.



Figure 2 ATP.



Figure 3 AHW.



Figure 4 AHC.



Figure 5 QSP.



Figure 6 QTP.



Figure 7 QHW.



Figure 8 QHC.



Figure 9 AHP.



Figure 10 AHPS.

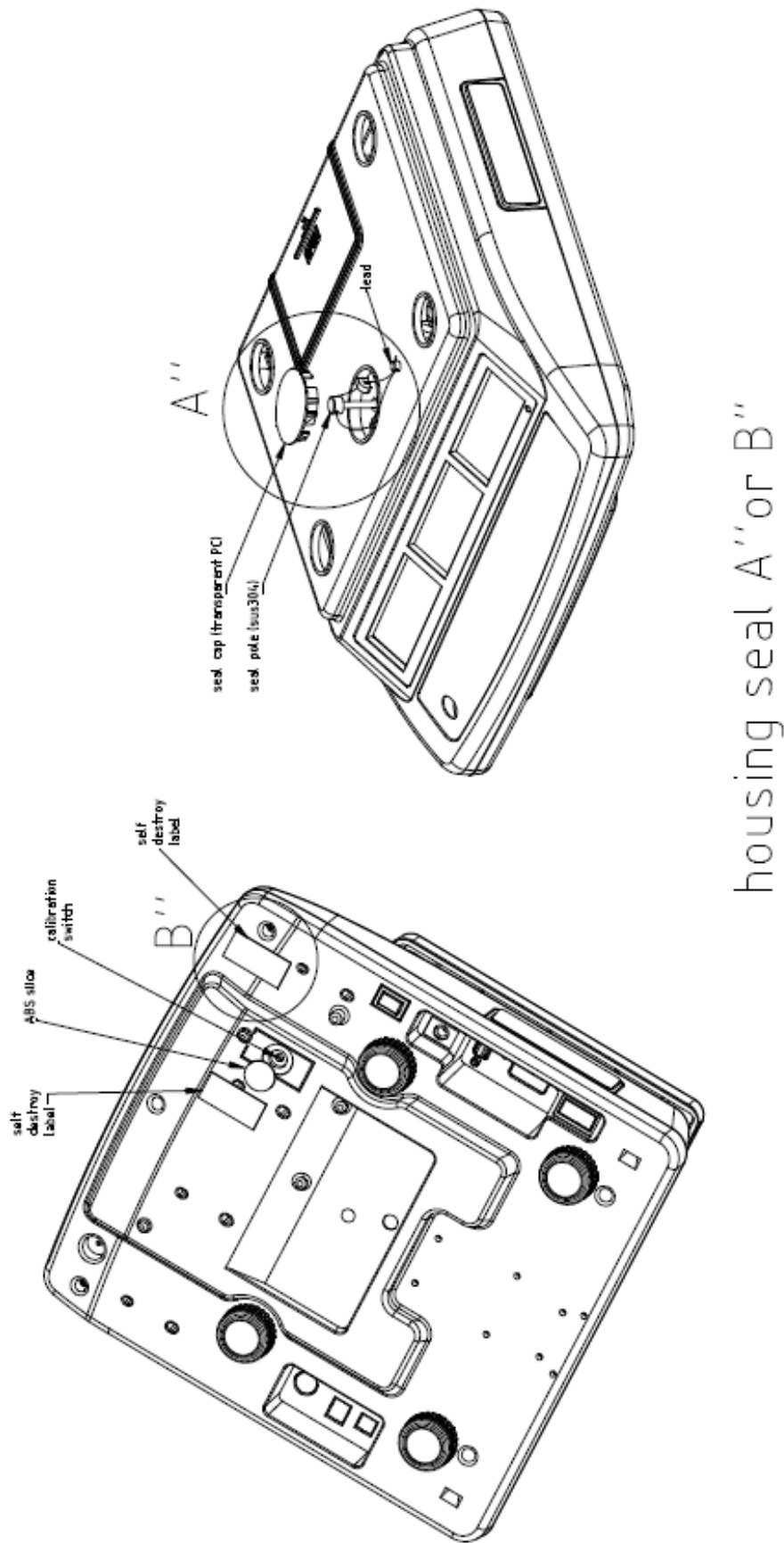

Figure 11 Sealing of ASP / ATP / AHW / AHC / AHP / AHPS scales.

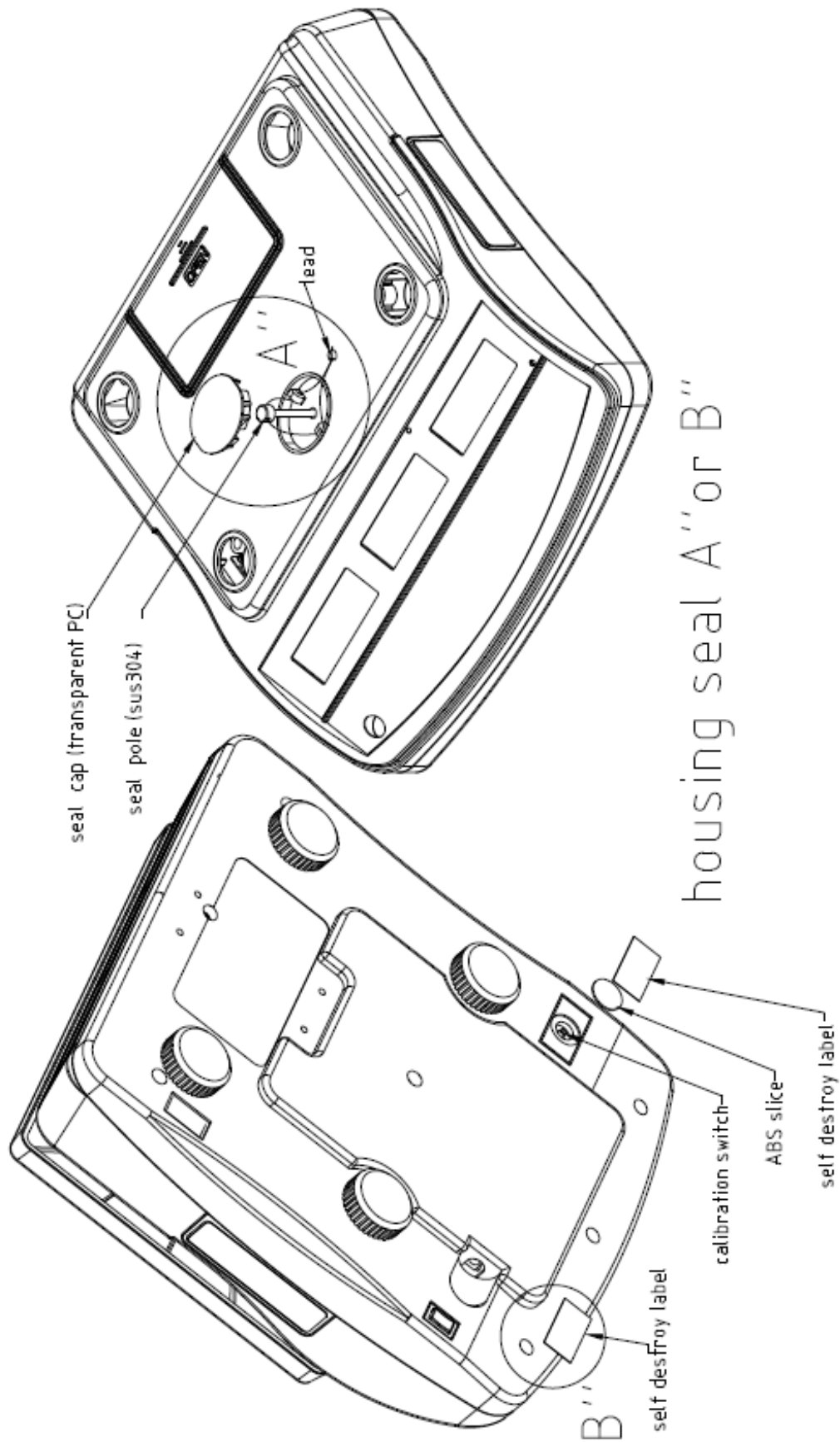

Figure 12 Sealing of QSP / QTP / QHW / QHC scales.